

TC Crown front direct [C3] is Controller.

TC Bottom before wall [B2] is Monitor.

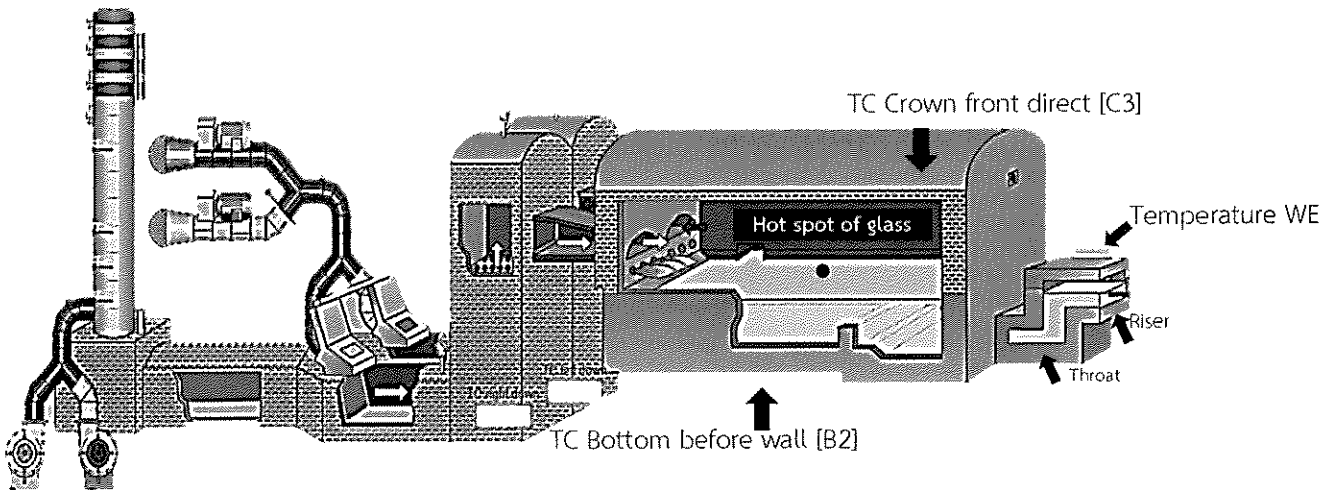

Condition Control List	ค่าครั้งก่อน	ค่าปัจจุบัน	Error is acceptable.	Unit
1.Pull Rate				Ton/Day
2.TC Crown front direct [C3]				°C
3.TC Bottom before wall [B2]				°C
4.Temperature WE				°C
5.Furnace Pressure				mmwg
6.Furnace Gas Pressure				mbar
7.OP. Hot Spot of glass				°C
8.Electrice Booster				kW
9.ความชื้นของแบทซ์ที่หน้า Batch Chargers				%
C3 Adjustment.				
10.Gas				Nm ³ /Hr.
Gas/Air ratio (Gas 10.8%, Air 100%)				%

Instructed By : _____

Manager or Engineer

Date